

Weigh Module

Model BMA Series

Specially Designed for
Hopper, Bin and Tank (20kg ~ 300kg)

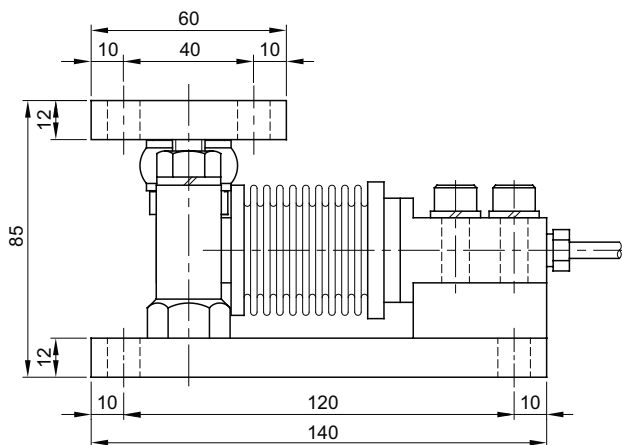
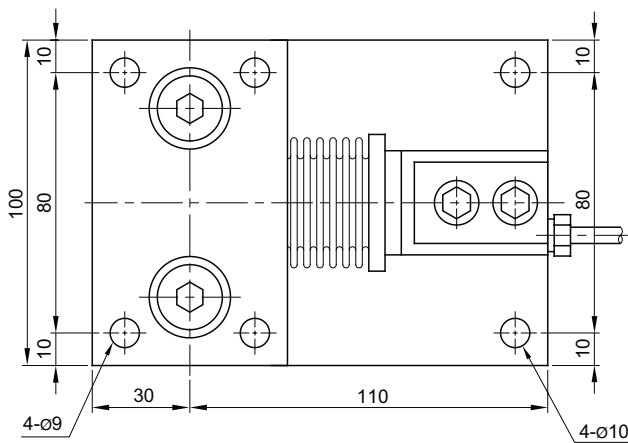
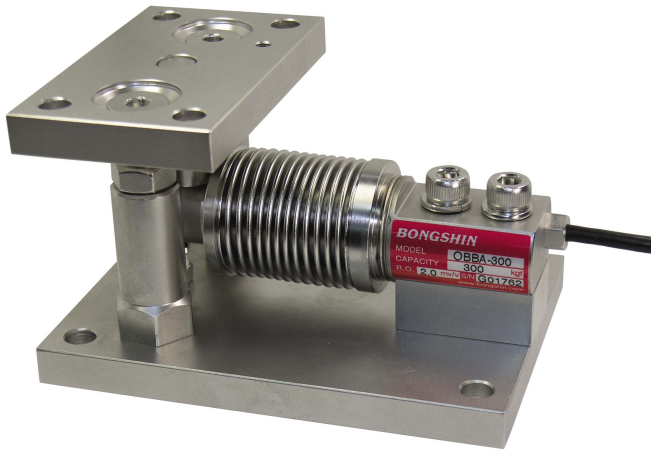

- Self centering design for accurate weighing.
- Self checking and overlift protection structure for no check rods needed.
- Fully welded stainless steel load cell.
- Stainless steel or zinc plated steel mounting kit.

SPECIFICATIONS

MODEL	BMA21, BMA22
Rated capacity (R.C.)	20, 50, 100, 200, 300kg
Rated output (R.O.)	2mV/V ± 0.3%
Non-linearity	≤ 0.03% R.O.
Hysteresis	≤ 0.02% R.O.
Non-repeatability	≤ 0.02% R.O.
Creep error	≤ 0.03% in 20min.
Zero balance	≤ 1% R.O.
Compensated temperature range	-10 ~ 70°C
Operating temperature range	-20 ~ 80°C
Temp. effect on rated output	≤ 0.02% LOAD/10°C
Temp. effect on zero balance	≤ 0.02% R.O./10°C
Terminal input resistance	400 Ohms ± 20 Ohms
Terminal output resistance	350 Ohms ± 5 Ohms
Insulation resistance (Min.)	2000 MOhms at 50V DC
Excitation voltage	10V(Recommended), 15V(Maximum)
Electrical connection	ø5mmx3m(22AWG x 4Core Shielded)
Protection class	meets IP 68
Safe overload	150% R.C
Ultimate overload	300% R.C

ORDERING INFORMATION

BMA21 - **50**
 MODEL CAPACITY
 20, 50, 100, 200, 300kg

BMA21 : OBBA Stainless Steel Load Cell + Zinc Plated Steel Mtg Kit
 BMA22 : OBBA Stainless Steel Load Cell + Stainless Steel Mtg Kit

WIRING INFORMATION

