

Model BS-5024P

Impact Dot Printer

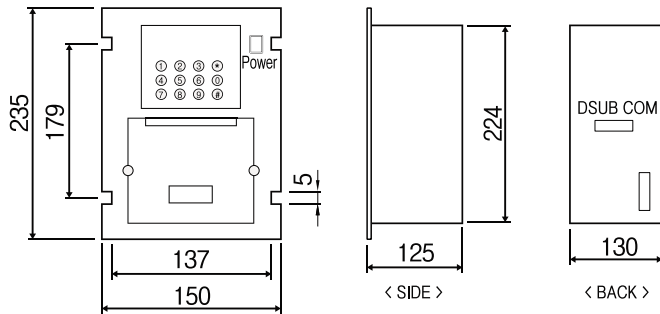

For:

- Industrial Weighing Applications

Features:

- Compact design
- Panel mount type
- High speed printing
- Year, date, time printing
- Sub, grand total printing
- 2 Color

SPECIFICATIONS

Printing method	Impact dot matrix
Number of columns	24C/40C
Printing width	24C : 57mm / 40C : 69mm
Printing speed	24C : 1.7 line/sec, 40C : 1.2 line/sec
Paper roll	57 x 60
Ink ribbon	ERC-09
Ink color	Black and red
Character size (W x H)	5 x 7 matrix
Interface	RS-232C serial
Power supply	AC free voltage

Model BS-6026

Impact Dot / Thermal Printer

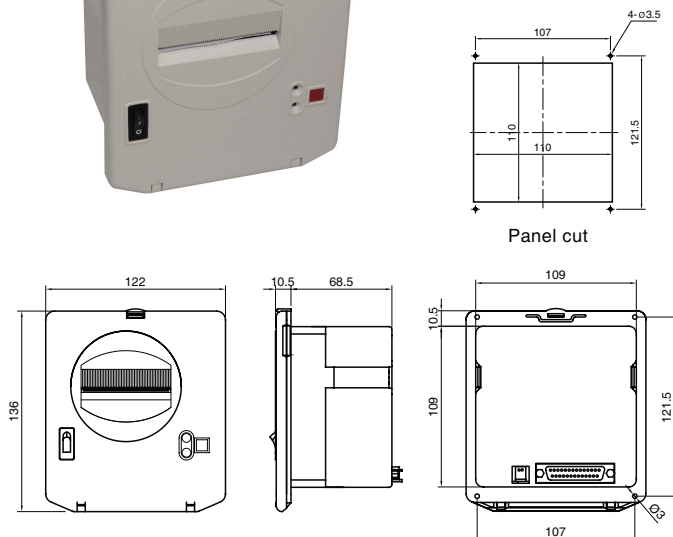

For:

- Industrial Weighing Applications

Features:

- Compact design
- Panel mount type
- High speed printing

SPECIFICATIONS

Printing method	Impact dot matrix	Thermal type
Number of columns	30/40 Columns	36 Columns
Printing width	57mm	
Printing speed	1.5 line / sec	
Paper roll	57 x 50	
Ink ribbon	ERC - 09	EPLK 1901
Ink color	Black	
Character size (W x H)	5 x 7 matrix	12 x 48 matrix
Interface	RS-232C serial / Parallel	
Operating Temperature	0 ~ 50°C	
Power supply	DC 12V (1.6A) / DC 5V (2.5A)	

* Specifications are subject to change without notice

JAN, 2010