

Model BSMP-120 Series

아나로그 트랜스미터

사 양

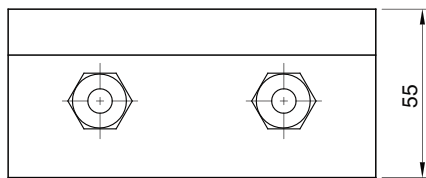
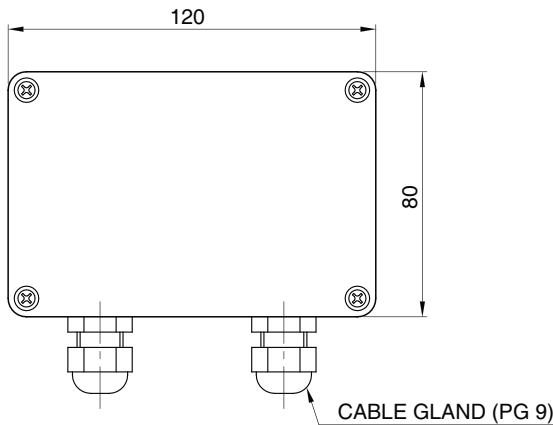

모 델	BSMP - 120A / BSMP - 120V
입력범위	0 ~ (+)1mV/V, (+)2mV/V, (+)3mV/V Selectable
로드셀 인가전압	DC 10V, 60mA (350 Ohms x 2 load cell)
출력	DC 0~10V, 4~20mA
비직선성	Within 0.03% of full scale
온도 특성	Zero : $\pm 0.2\mu\text{V}/^\circ\text{C}$ RTI max. Span : 10ppm/ $^\circ\text{C}$ max.
사용온도범위	-10 ~ 40 $^\circ\text{C}$
전 원	DC 24V (DC 15V ~ DC 30V)
케이스 재질 & 밀폐 등급	ABS, meets IP 67
중 량	230g

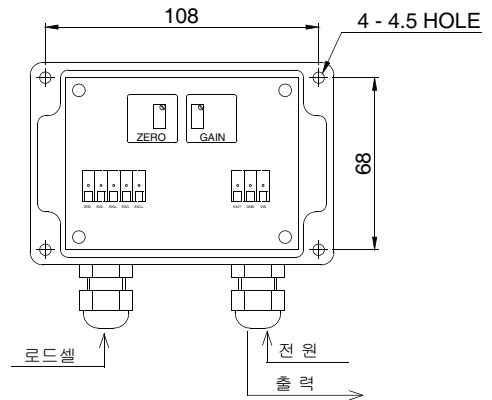

형식명	
BSMP	120A
└ 모델	└ 출력
BSMP	120A : DC 4~20mA
	120V : DC 0~10V

결선도

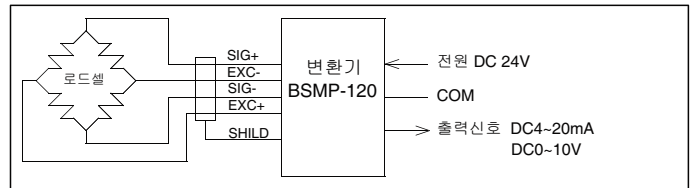

Model PT350C Series

아나로그 트랜스미터

사 양

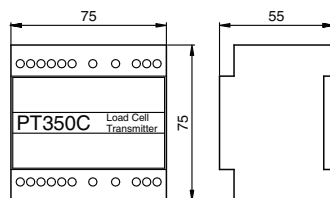

모 델	PT350C
적용 로드셀	All strain gauge type
입력 범위	0 ~ (+)1.5mV/V, (+)3mV/V Selectable
로드셀 인가전압	DC 10V, 120mA (350 Ohms x 4 load cell)
출력	DC 0~5V/0~10V, 0~20mA/4~20mA
비직선성	Within 0.05% of full scale
사용온도범위	-10 ~ 40 $^\circ\text{C}$
전 원	DC 24V $\pm 10\%$
케이스재질 & 밀폐등급	ABS, meets IP 54
중 량	150g